

Features

- 7.5 mm seated height
- Distortion of only 0.015 %
- Vacuum encapsulated
- Weight - 2 g
- UL60950 approved
- RoHS compliant*

Applications

- Modems (V34 and V92)
- Laptop Computers
- Telecommunications
- Instrumentation

SM-LP-5002 Series - Surface Mount Line Matching Transformers

Electrical Specifications

Nominal Impedance 600 Ω
 Turns Ratio 1:1
 Insertion Loss 2.0 dB max. at 2 kHz
 Frequency Response ±0.25 dB max. 200-4 kHz
 Return Loss 24 dB min. 200-4 kHz*
 Balance 80 dB min.
 Distortion -85 dB max.
 @ 600 Hz, -10 dBm
 Dielectric Strength...2000 VRMS for 1 min.
 Insulation Resistance 100 MΩ @ 500 V
 DC Resistance**
 Primary 136 Ω ±12 %
 Secondary 136 Ω ±12 %
 Shunt Inductance 3.8 H min.
 Shunt Loss 7500 Ω min.
 Leakage Inductance ...6-7 mH typ. @ 1 kHz
 Power Level 10 dBm
 Operating Temperature...-20 °C to +85 °C
 Storage Temperature.....-40 °C to +85 °C

Materials

Terminal Plating Sn/Ag/Cu

*For use with recommended circuit (BS6305 impedance Class A non-speech or Class B speech).

**SM-LP-5002 is symmetrical, meaning there is no real primary nor secondary winding.

Product Dimensions

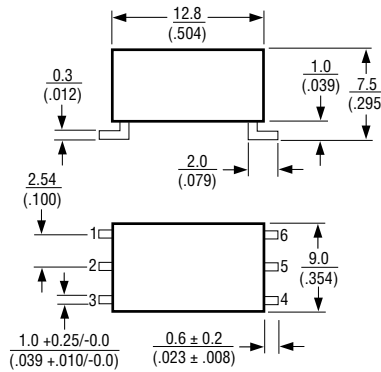

Suggested PCB Layout

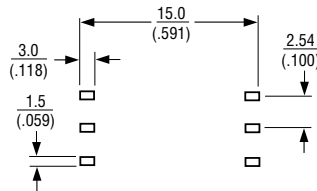

DIMENSIONS: $\frac{\text{MM}}{\text{(INCHES)}}$

LEAD COPLANARITY: $\frac{0.15}{(0.006)}$ MAX.

UNLESS OTHERWISE SPECIFIED, TOLERANCE: $\frac{\pm 0.25}{(0.010)}$ MAX.

How To Order

Model **SM-LP-5002**
 Packaging _____
 Blank = Packaged in tubes
 E = Tape and reel (400 pcs. per reel)

Schematic

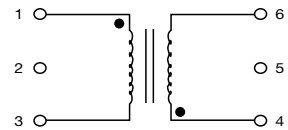

Solder Profile

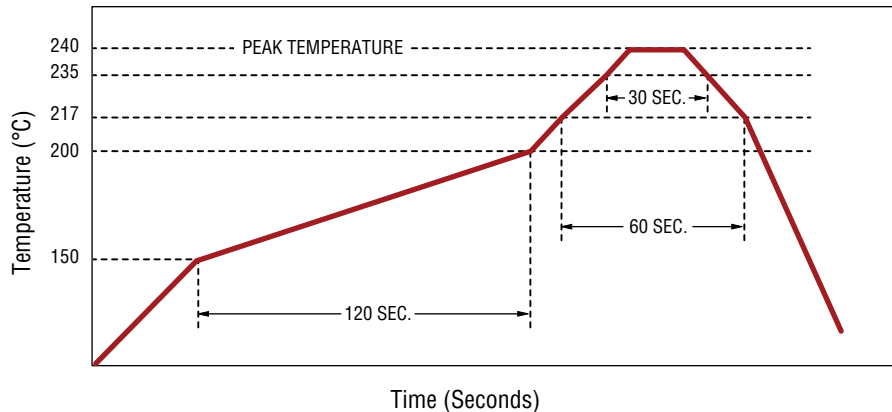

*RoHS Directive 2002/95/EC Jan. 27, 2003 including annex and RoHS Recast 2011/65/EU June 8, 2011.

Specifications are subject to change without notice.

The device characteristics and parameters in this data sheet can and do vary in different applications and actual device performance may vary over time. Users should verify actual device performance in their specific applications.

SM-LP-5002 Series - Surface Mount Line Matching Transformers

BOURNS®

Packaging Specifications

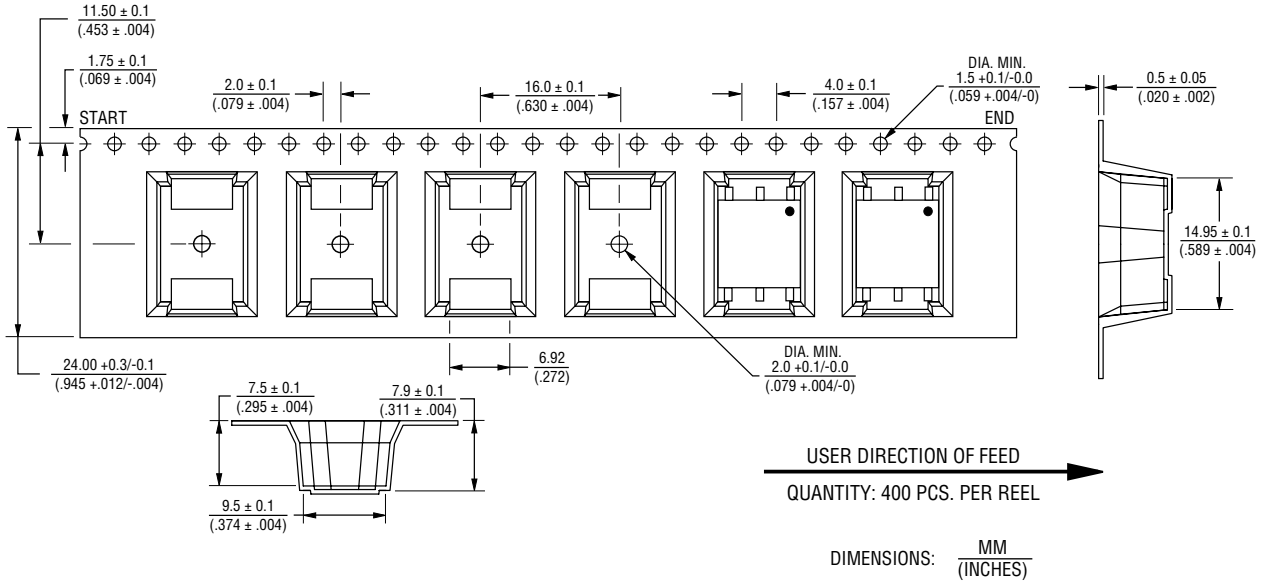

REV. 05/17

Specifications are subject to change without notice.
 The device characteristics and parameters in this data sheet can and do vary in different applications and actual device performance may vary over time.
 Users should verify actual device performance in their specific applications.